

SECTION C-C

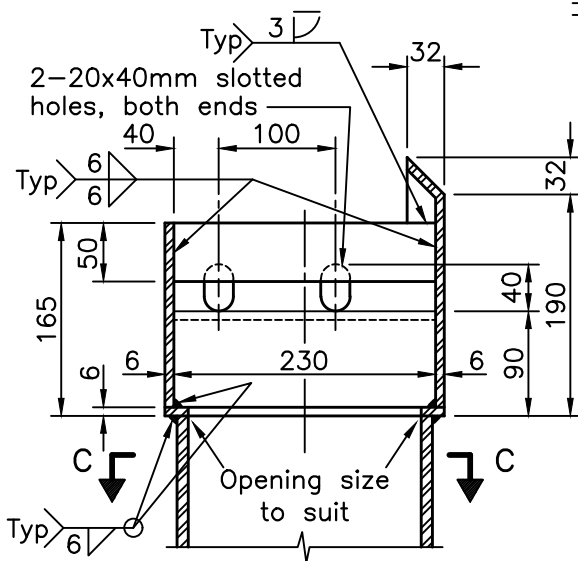

CATCH BASIN DETAILS

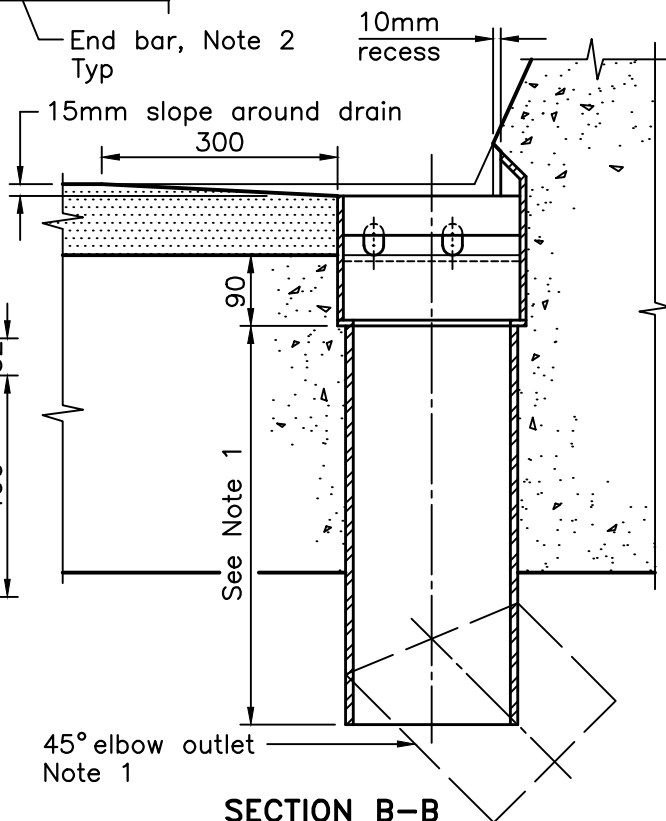

SECTION B-B

NOTES:

- 1 Shape and length of downspout as specified. When the drain location conflicts with end of barrier form, drain may move a maximum of 1.5m along length of barrier.
- 2 End bars shall be 12x38mm steel bar and centre bars shall be 12x50mm steel bar.
- A After fabrication, drains shall be hot-dip galvanized as specified.
- B Pipe shall be according to ASTM A53M, Grade B.
- C Steel bar shall be according to ASTM A53M, Grade B.
- D All welding shall be of a low hydrogen classification and according to CSA W59.
- E All dimensions are in millimetres unless otherwise shown.

ONTARIO PROVINCIAL STANDARD DRAWING

Nov 2022

Rev 3

DECK
DRAINS

WITH TRANSVERSE BAR OPENINGS



OPSD 3340.150